

# NEMA Type 12 Screw Cover Trough

## Screw Cover Trough

### Application

- ◆ Intended for outdoor use
- ◆ Provides protection against windblown dust and windblown rain

### Construction

- ◆ 14 or 12 gauge steel
- ◆ Flanged removable cover fastened with stainless steel screws
- ◆ Seams continuously welded and ground smooth
- ◆ Oil resistant gasket & adhesive
- ◆ Grounding stud on inside of enclosure
- ◆ External mounting feet
- ◆ No holes or knockouts
- ◆ Optional back panel



### Finish

- ◆ ANSI 61 gray polyester powder coating inside and out over phosphatized surfaces
- ◆ Optional inner panel is white powder coat

### Standards

- ◆ UL 508 Type 3 & 12
- ◆ NEMA Type 3 & 12
- ◆ IEC 60529, IP66

### Modification and Options

- ◇ Enclosure height, width, and depth
- ◇ Back panel

Enclosure Catalog Number	Body Gauge	Size HxWxD	Enclosure Catalog Number	Body Gauge	Size HxWxD
MCF-N12-040424-SCT	14	4x4x24	MCF-N12-121248-SCT	14	12x12x48
MCF-N12-060624-SCT	14	6x6x24	MCF-N12-121260-SCT	14	12x12x60
MCF-N12-060636-SCT	14	6x6x36			
MCF-N12-060648-SCT	14	6x6x48			
MCF-N12-080824-SCT	14	8x8x24			
MCF-N12-080836-SCT	14	8x8x36			
MCF-N12-080848-SCT	14	8x8x48			
MCF-N12-121236-SCT	14	12x12x36			



**METAL CABINET AND FIXTURE COMPANY**

a **Span-O-Matic, Inc.** Company

825 COLUMBIA STREET, BREA, CA 92821

PHONE: 714-256-4700 FAX: 714-256-4401

WWW.SPANOMATIC.COM

WWW.METALCAB.COM

MCF-N12-SCT

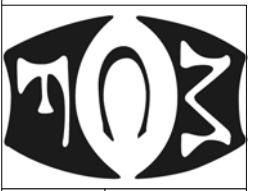
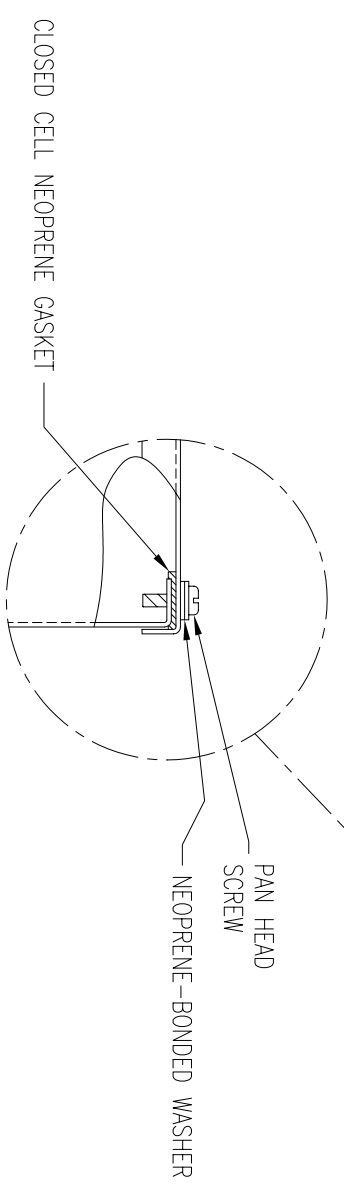
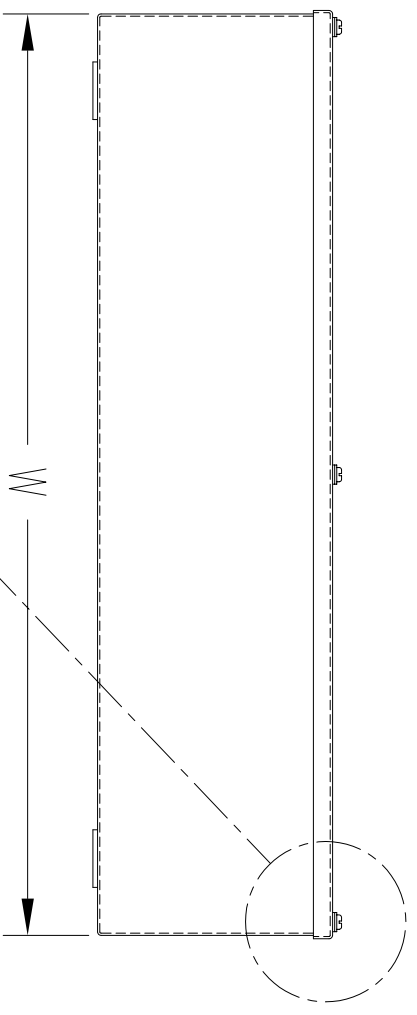
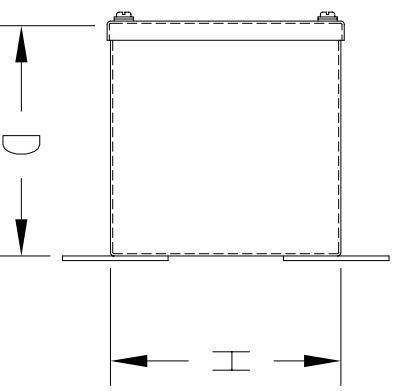
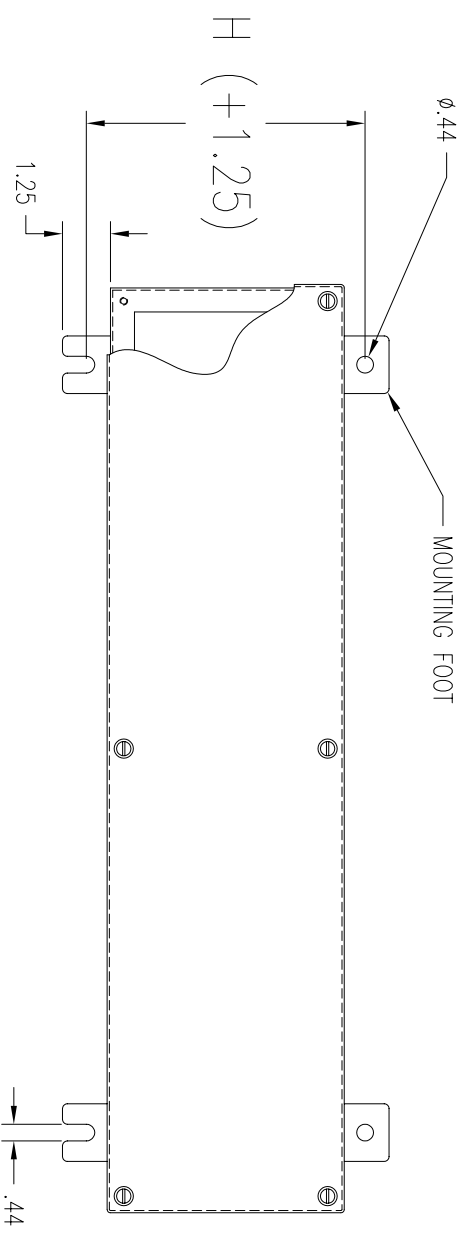

**METAL CABINET & FIXTURE CO.**  
 825 COLUMBIA ST., BREA, CA 92821  
 (714) 256-4700

**MCF-N12-SCT**