

# NEMA Type 12 and Type 13

## Single-Door Enclosures

### Application

- ◆ Intended for indoor use
- ◆ Protects against dust, falling dirt, and dripping non-corrosive liquids

### Construction

- ◆ Enclosure and door are fabricated from code gauge steel
- ◆ All doors are 14 gauge steel
- ◆ Seams continuously welded and ground smooth
- ◆ Continuous hinged door
- ◆ Door is secured with stainless steel clamps
- ◆ Provision for padlocking
- ◆ Oil-resistant gasket and adhesive
- ◆ External mounting feet
- ◆ No holes or knockouts (see options)
- ◆ Data pocket
- ◆ Collar studs provided for optional back panel
- ◆ Door and body stiffeners in larger enclosures

### Finish

- ◆ ANSI 61 gray polyester powder coating inside and out over phosphatized surfaces
- ◆ Optional inner panel is white powder coat

### Standards

- ◆ UL 508 Type 12 and Type 13
- ◆ NEMA Type 12 and Type 13
- ◆ IEC 60529, IP65



### Modification and Options

- ◆ Enclosure height, width, and depth
- ◆ Holes and cutouts
- ◆ Louvers, filters and fans
- ◆ Windows
- ◆ Floor stand kits
- ◆ Drip shield

Enclosure Catalog Number	Body Gauge	Size HxWxD	Enclosure Catalog Number	Body Gauge	Size HxWxD
MCF-N12-241206-SD	16	24x12x6	MCF-N12-242012-SD	14	24x20x12
MCF-N12-242006-SD	16	24x20x6	MCF-N12-242412-SD	14	24x24x12
MCF-N12-242406-SD	16	24x24x6	MCF-N12-362412-SD	14	36x24x12
MCF-N12-362406-SD	14	36x24x6	MCF-N12-363612-SD	14	36x36x12
MCF-N12-241208-SD	16	24x12x8	MCF-N12-482412-SD	14	48x24x12
MCF-N12-242008-SD	14	24x20x8	MCF-N12-483612-SD	14	48x36x12
MCF-N12-242408-SD	14	24x24x8	MCF-N12-483616-SD	14	48x36x16
MCF-N12-362408-SD	14	36x24x8	MCF-N12-483624-SD	14	48x36x24



**METAL CABINET AND FIXTURE COMPANY**

a **Span-O-Matic, Inc.** Company

825 COLUMBIA STREET, BREA, CA 92821

PHONE: 714-256-4700 FAX: 714-256-4401

WWW.SPANOMATIC.COM

WWW.METALCAB.COM

MCF-N12-SD

Type 12 & 13 Single Door Enclosure

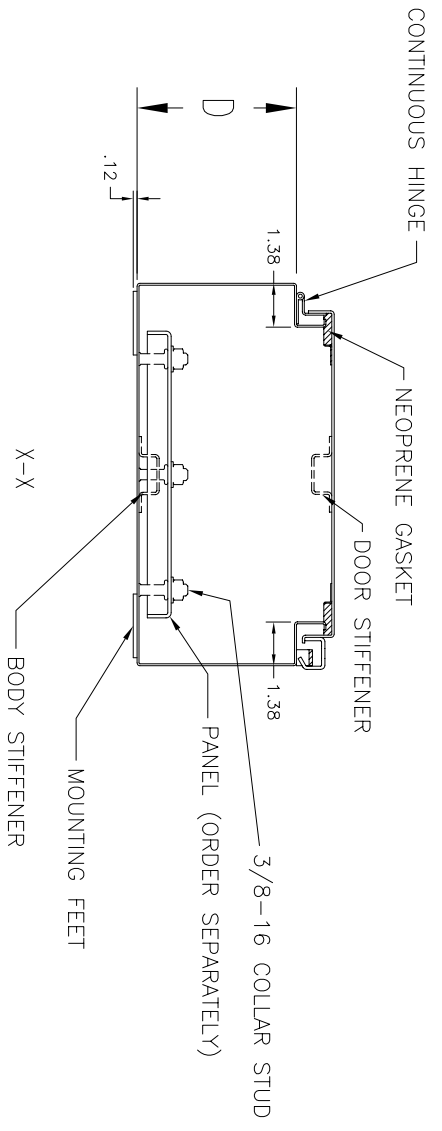
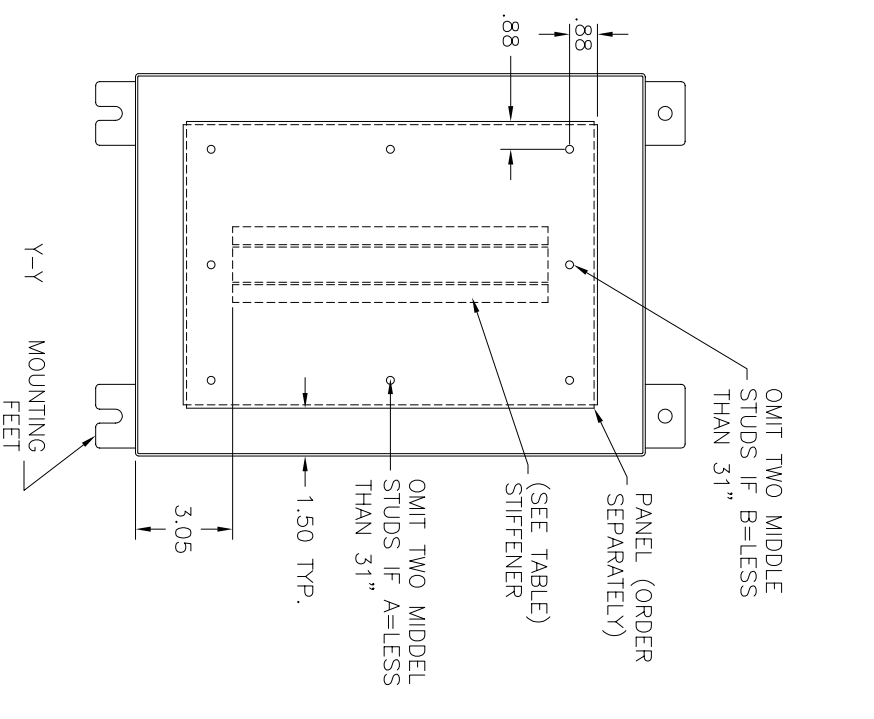
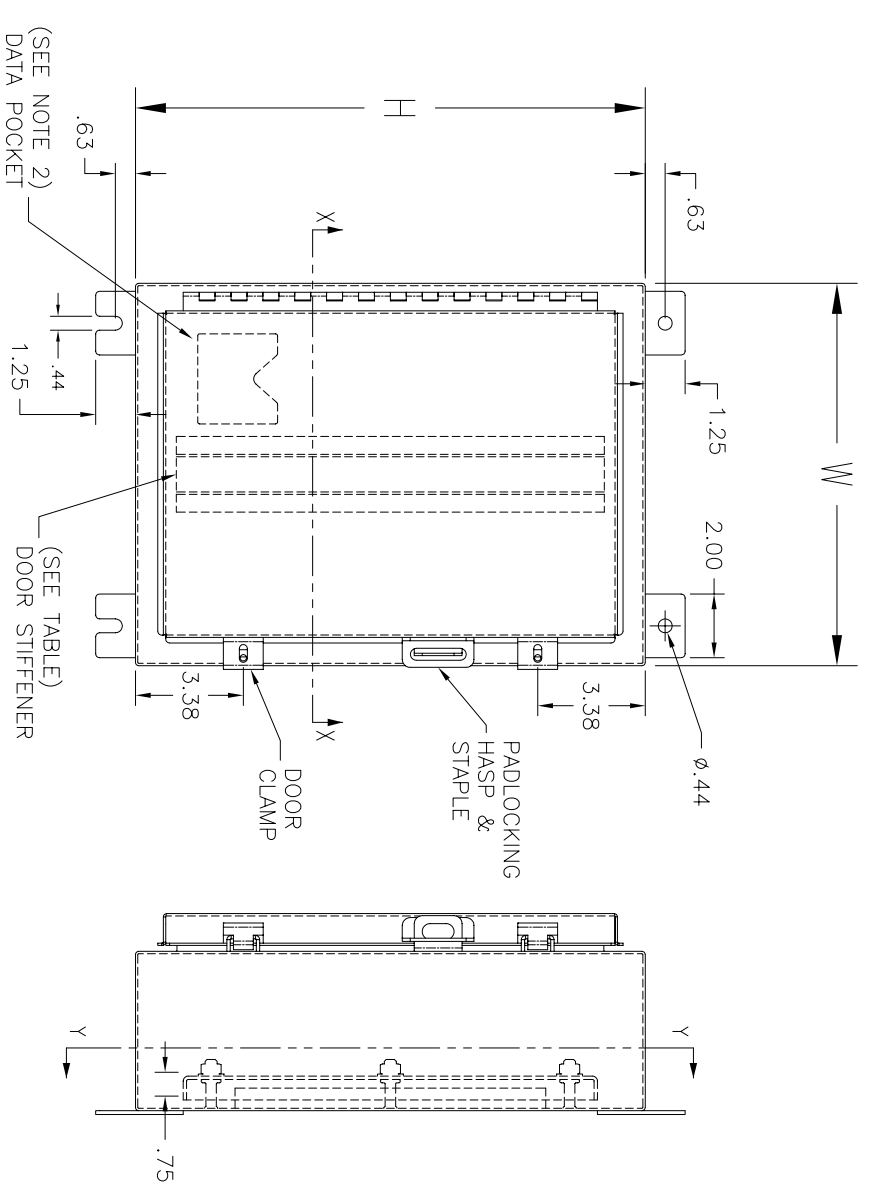

- NOTES:
1. PANELS ARE 12 GAUGE STEEL
  2. SMALL DATA POCKET 6.0 X 6.0  
LARGE DATA POCKET 9.0 X 9.0

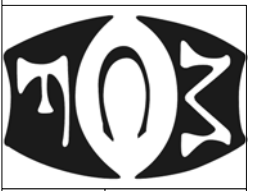

**METAL CABINET & FIXTURE CO.**  
 825 COLUMBIA ST., BREA, CA 92821  
 (714) 256-4700

**MCF-N12-SD**